

TRAVERSING UNLOADER



The Traversing Unloader is designed to assist the unloading of cargo and baggage containers and delivery trucks at a conveyor belt. It is mounted on t-rails adjacent to the conveyor to allow the unit to traverse to several different stations. The unloader telescopes, providing a roller conveyor surface for the unloading of containers or delivery vans.

FEATURES:

- Movable on t-rail to accommodate several locations
- Heavy duty construction to provide long life
- Unit is counter-balanced with torsion springs for ease of operation
- Steel rollers in high impact areas
- Unit stores in upright position to allow personnel passage and movement between vans, trucks and stations

“FIRST CLASS DOESN'T HAVE TO COST MORE”



WASP, Inc.
Box 249 ■ Glenwood, MN 56334
(320) 634-5126 FAX (320) 634-5891
www.waspinc.com

TRAVERSING UNLOADER

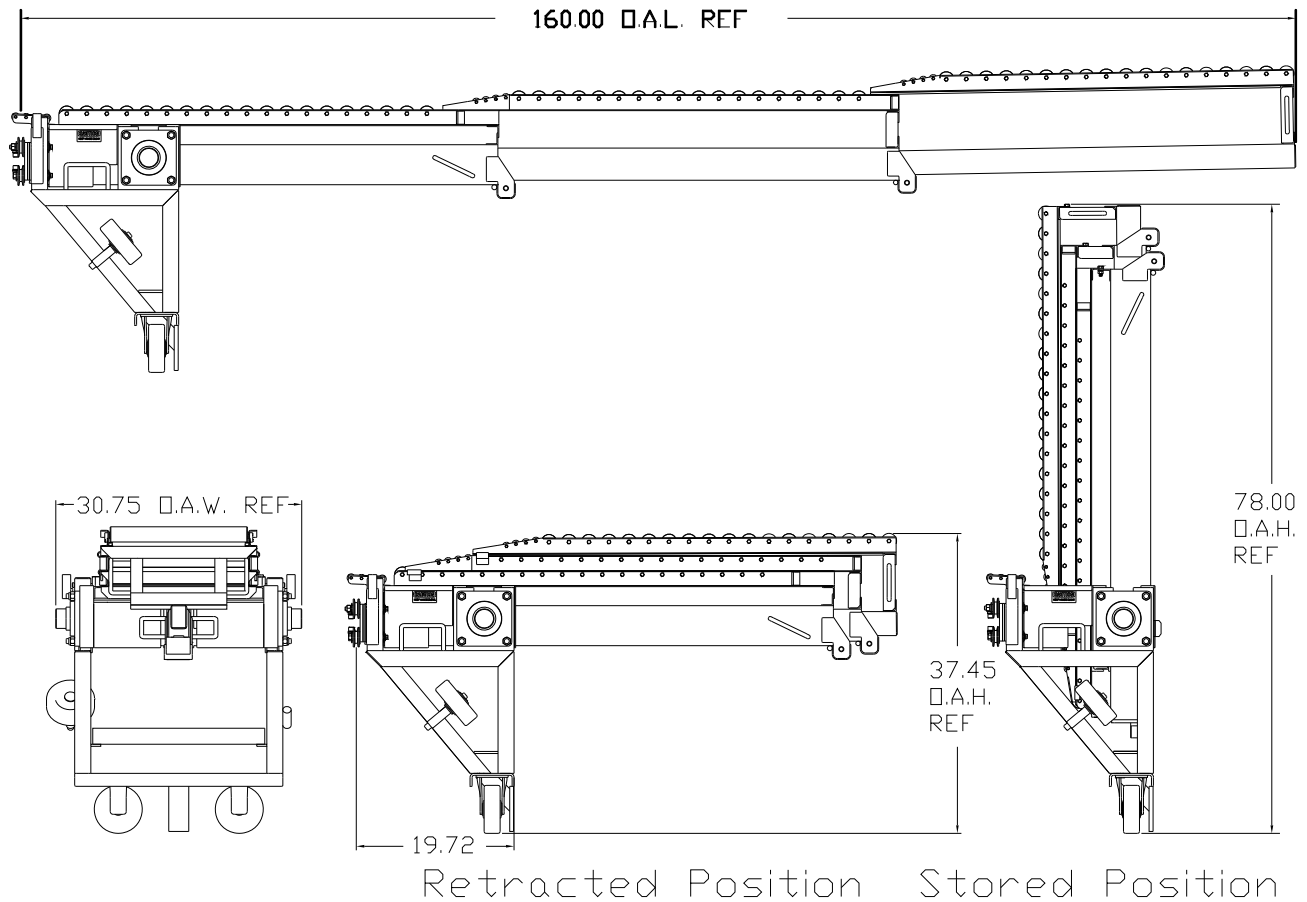

30 Inch Elevation Standard; Other Elevations are Available.

SPECIFICATIONS:

FRAME: All Steel Construction, 17.50 Inches Between Frame.

ROLLERS: PVC Rollers with Steel Rollers in High Impact Areas;
17.00 Inches Wide, 2.50 Inches on Center, 1.90 Inch Diameter.

CAPACITY: 50 Pounds per Linear Foot.

DIMENSIONS FROM T-RAIL:

RETRACTED

EXTENDED

67.5"

13'4"



WASP, Inc.
Box 249 ■ Glenwood, MN 56334
(320) 634-5126 FAX (320) 634-5891
www.waspinc.com