

Single-Stage Extendable Conveyor for Loading/ Unloading ULDs

Maximize package transfer rates for ULDs.

Single-stage belt-drive conveyor provides automatic movement of packages for more efficient loading or unloading of cargo containers and ULDs. Manual extension/retraction allows boom to stop in position at any length, up to a max of 6 ft. 6 inches to reach inside container for ease of operation. Hydraulic work height adjustment raises or lowers boom extension to align with package elevation changes for increased performance and operator safety.

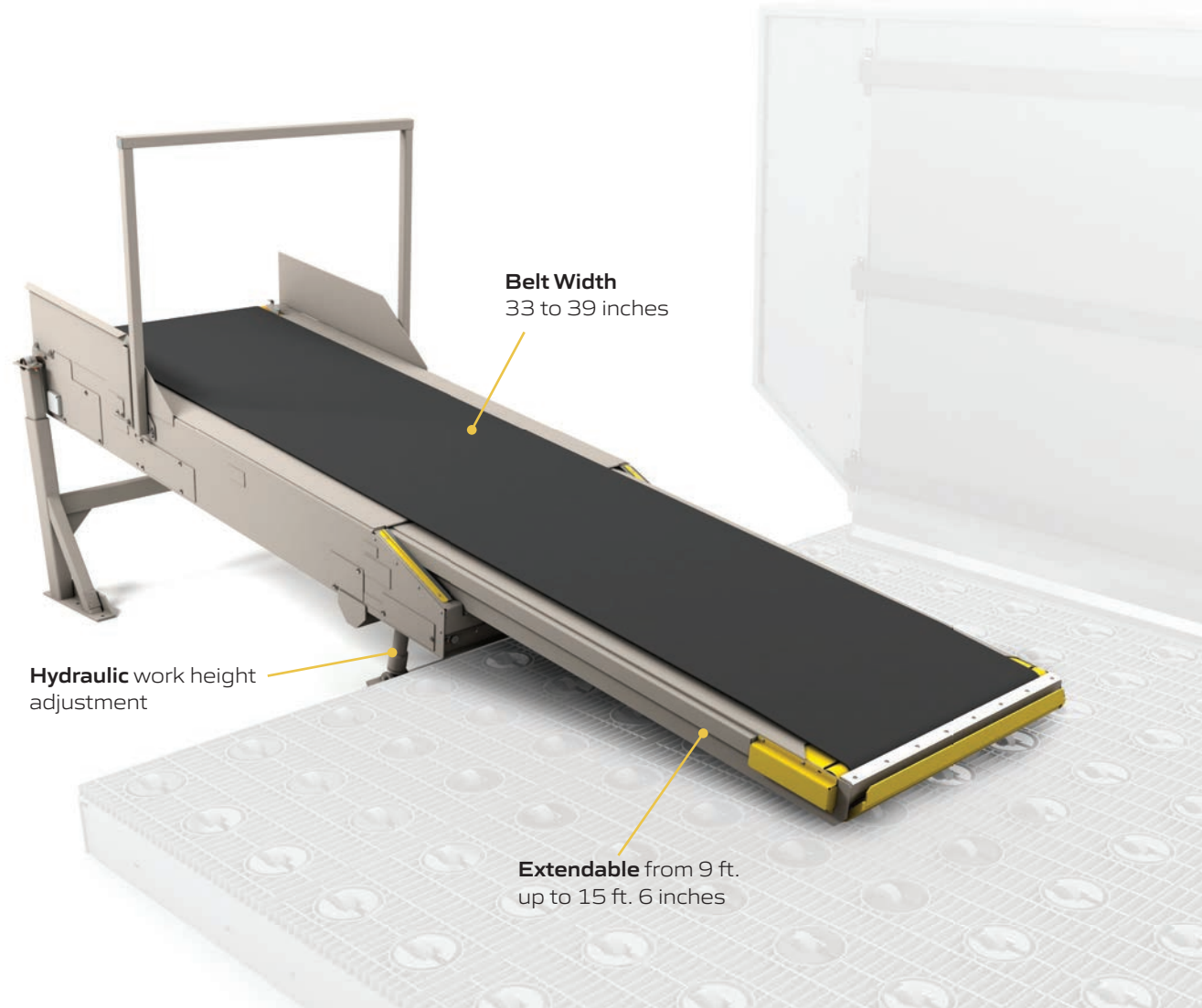

SPECIFICATIONS

Retractable Length: 9 ft.

Extendable Length: 15 ft. 6 inches

Belt Width: 33 to 39 inches

Belt Direction: Load, Unload or Bi-Directional

Belt Speed: 60 fpm

Operation: Hand Crank Boom Extension

Boom End Elevation: 20 to 28 inches

Load Capacity: 50 lbs./ft.

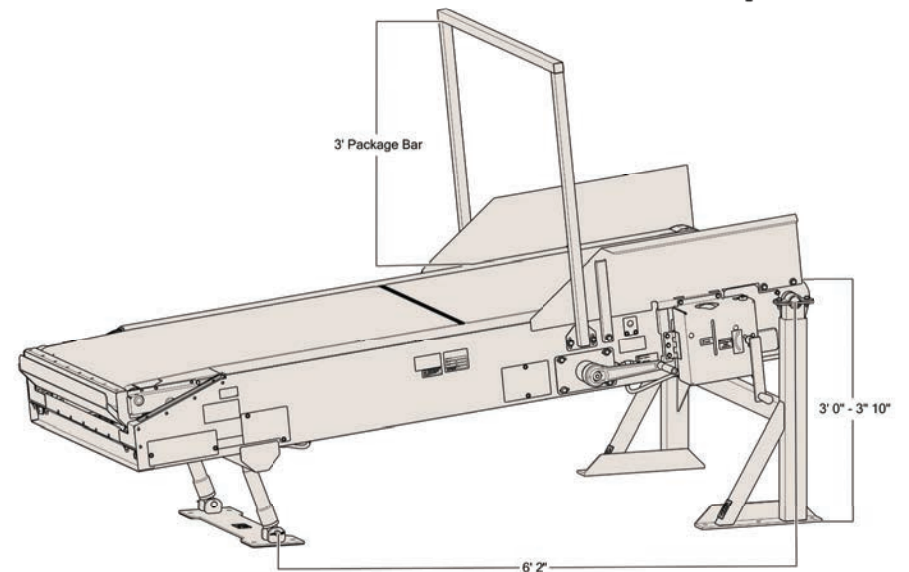
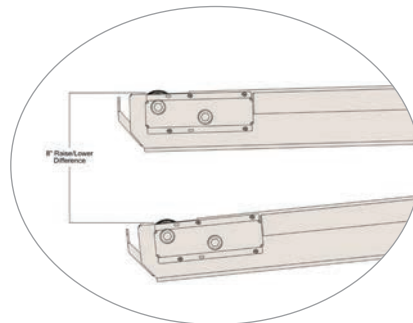
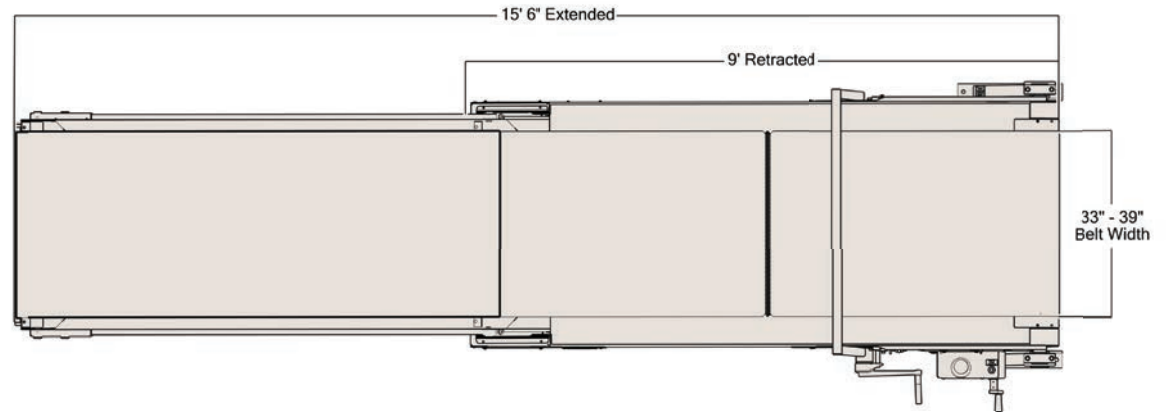

AIRCRAFT LOAD/UNLOAD
FREIGHT TRANSFER
CONVEYING OPERATIONS
ULD/PALLET MANEUVERABILITY

A world leader in airline, air cargo and material handling equipment for over 40 years, FAST Global Solutions designs, builds, installs and services an expansive portfolio of robust, ruggedly-built, dependable equipment for today's global commerce operations.

To learn more, contact the knowledgeable and experienced FAST Team:

conveyorsales@fastsolutions.com +1 (320) 634-5126 fastsolutions.com